



DESTROYER GRINDER
Built for Strength

HF-5340LR
HF-6850LR
HF-7860LR

**CUSTOM MADE
IN THE U.S.A.**

Plastic Recycling
Plastic Purgings
Plastic Recycling



HF-5340LR, HF6850LR, HF7860LR HOPPER FEED SHREDDERS

These “Destroyer” models are heavy-duty top feed shredders equipped with 40” to 60” rotor length, 16” diameter V-rotor cutterhead, innovative ram and control technology to maximize through-put and to accommodate and destroy small, medium and large-sized materials. These rugged machines are built to solve the size reduction needs for plastic reclaim and recycling, and plastic purgings.

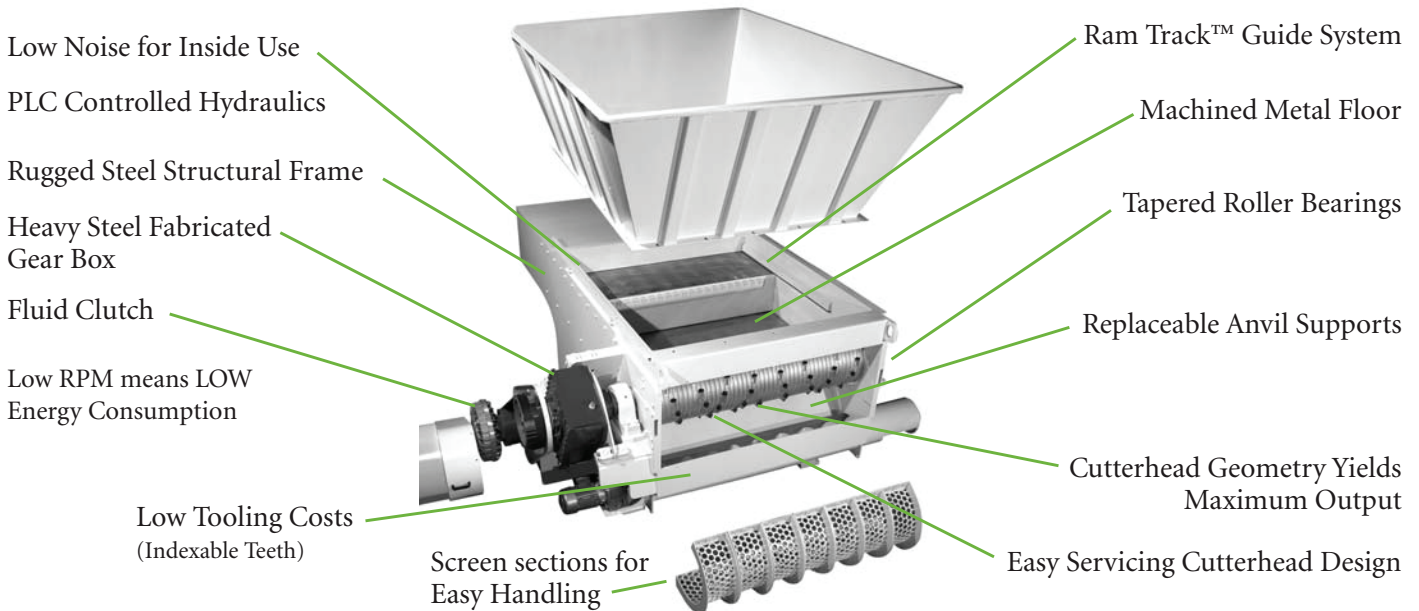

Specifications

	HF-5340LR	HF-6850LR	HF-7860LR
Motor HP	40, 50, 60	50, 60, 75	75, 100, 125
Cutting Chamber	40" x 53"	50" x 66"	60" x 77"
Ram Stroke	36"	50"	60"
Grinding Head Diameter	16"	16"	16"
Grinding Head Speed	50-150 rpm	50-150 rpm	50-150 rpm
Frame Thickness	3/4"	3/4"	3/4"
No. of Cutter Teeth	56	70	84
Shaft Diameter	4"	4"	4.5"
Hopper Opening	64" x 75"	50" x 78"	60" x 88"
Floor Area of Unit	89" x 125"	97" x 148"	100" x 150"
Shipping Weight	10,000 lbs.	13,500 lbs.	17,500 lbs.
Specifications are subject to changes			

Machines shown with options



55 W. Lincoln Highway • Cortland, Illinois 60112
800-962-7302 • Fax: 815-758-0733 • www.cresswood.com